

# COBRA<sub>2K</sub> User Guide

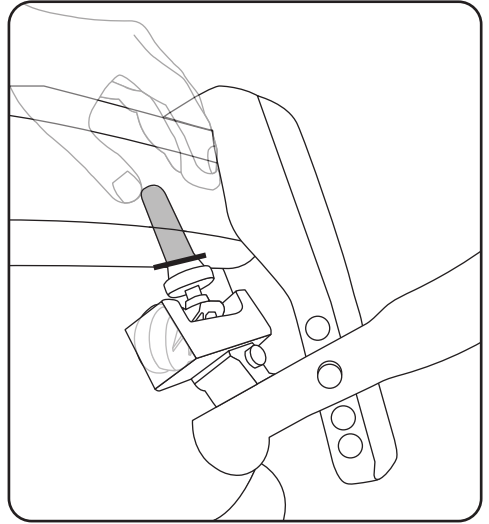

**1** Input rubber valve stem into wheel



**2** Mount sensor body by holder

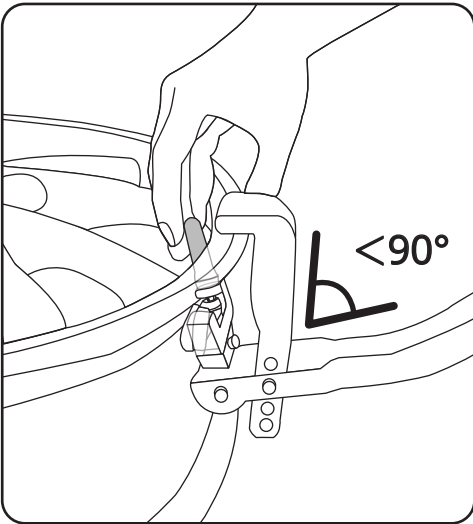

**3** Hold rubber valve stem and make sure angle is less than 90 degree

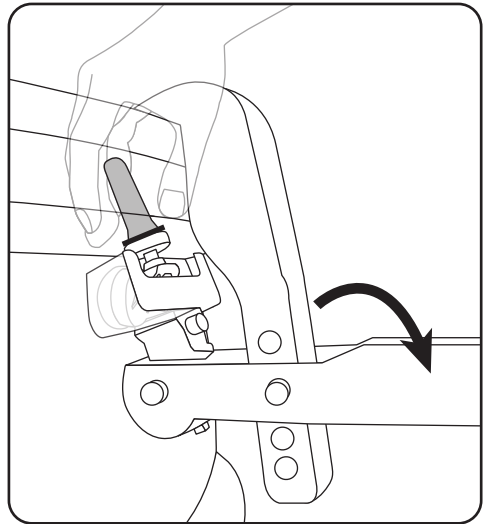

**4** Hold rubber valve stem and pull handle to fit snap-in sensor

# COBRA<sub>2K</sub> User Guide

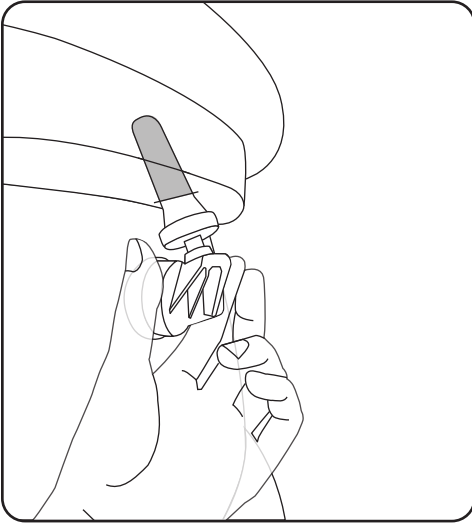

**1** Gummiventil in Felge einsetzen

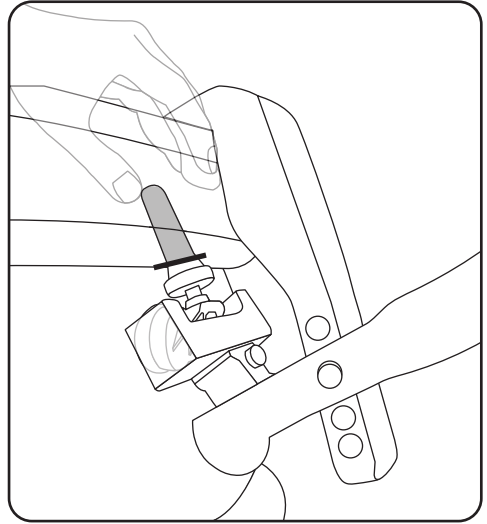

**2** Sensor mit richtigem Halter greifen

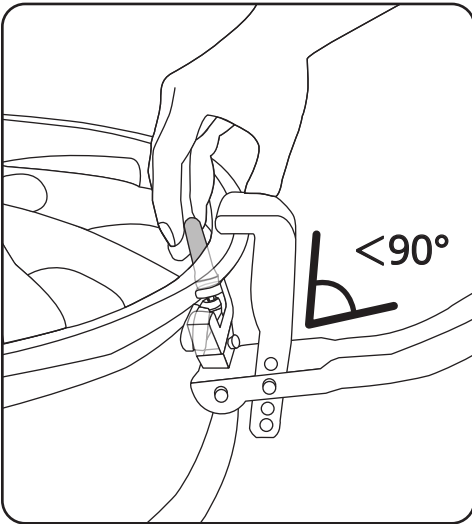

**3** Gummiventil festhalten. Der Winkel muss kleiner als  $90^\circ$  sein

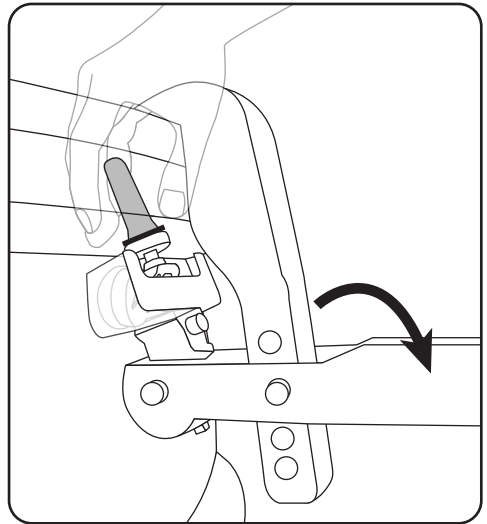

**4** Gummiventil festhalten und Hebel betätigen bis Ventil mit Sensor sitzt

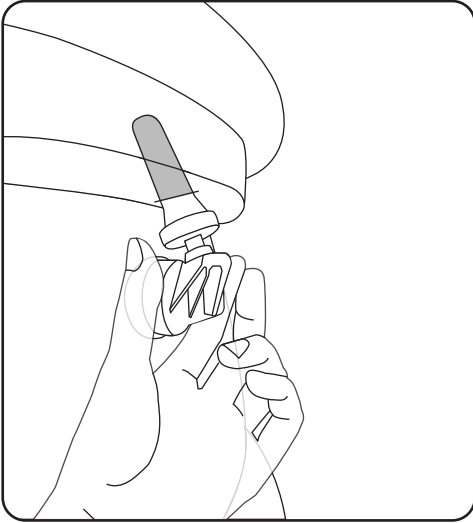

**1** Inserire sensore e valvola nel cerchio

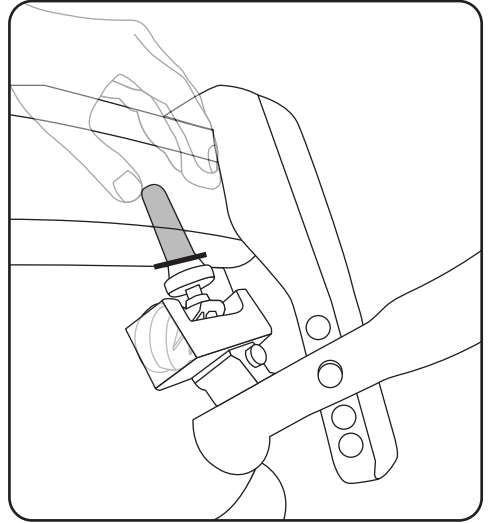

**2** Inserire il corpo del sensore direttamente nel supporto dello strumento Cobra 2K

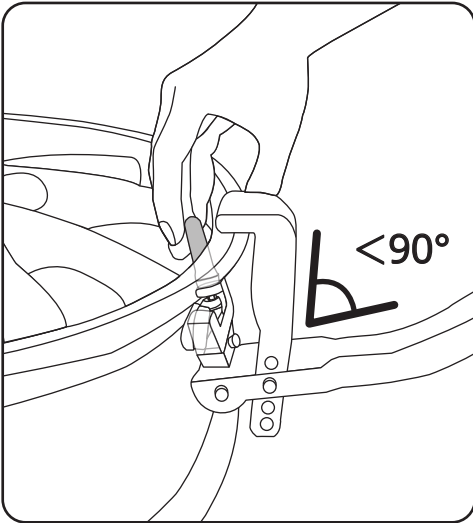

**3** Tenere in mano la valvola in gomma e assicurarsi che l'angolo dello strumento sia meno di 90 gradi

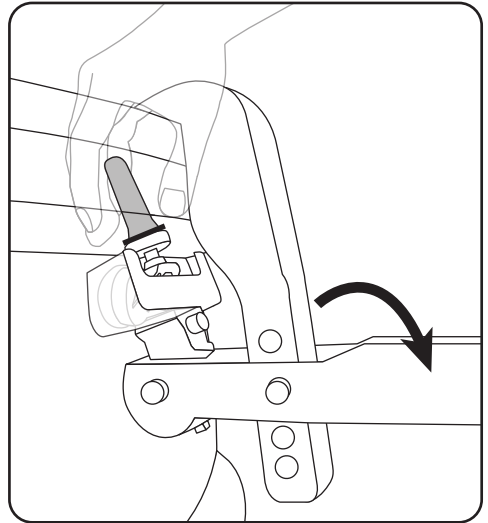

**4** Spingere la maniglia del Cobra 2K per inserire il sensore con valvola in gomma - snap-in

# COBRA 2K 操作說明書

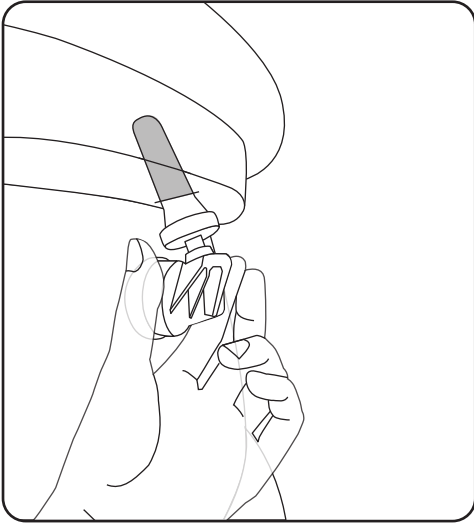

**1** 將橡膠氣嘴穿過鋁圈氣嘴孔

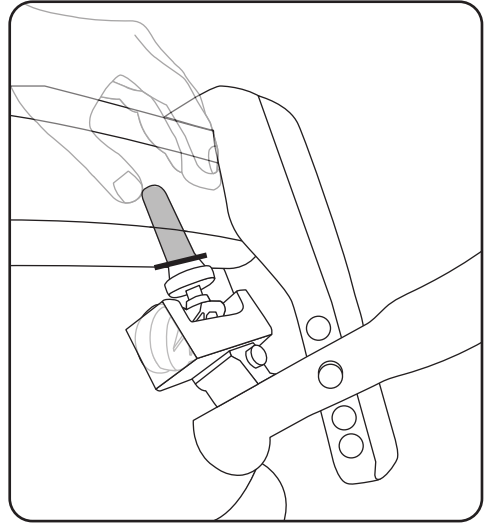

**2** 將發射器正確置放於Cobra 2K的固定座

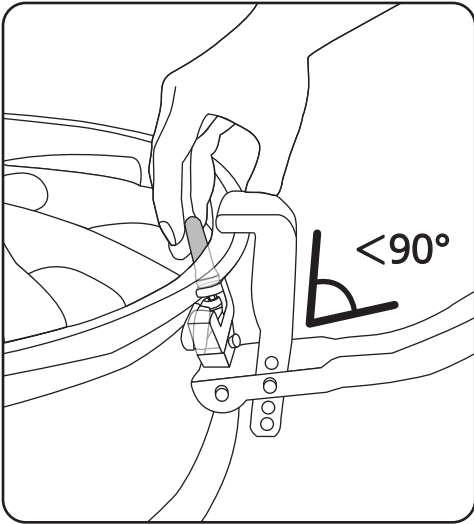

**3** 發射器固定後，請確認Cobra 2K的角度小於90度

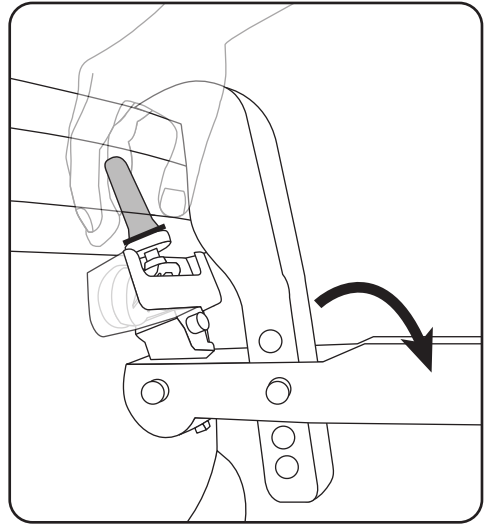

**4** 固定橡膠氣嘴，手柄下壓將橡膠氣嘴安裝至正確位置，即完成安裝過程。

# COBRA 2K 操作说明书

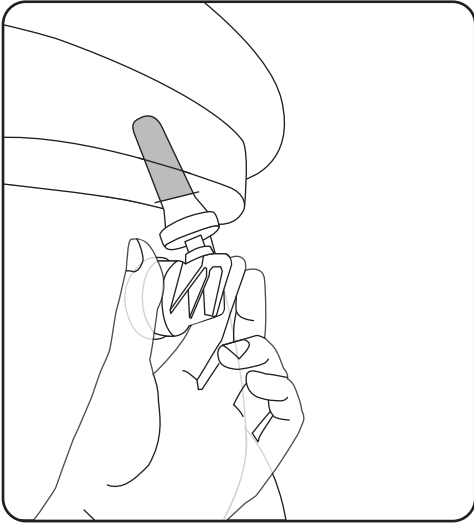

**1** 将橡胶气嘴穿过轮毂气嘴孔

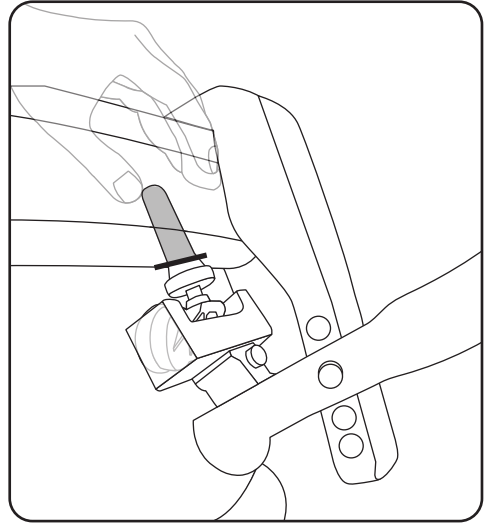

**2** 将传感器正确置放于Cobra 2K的固定座

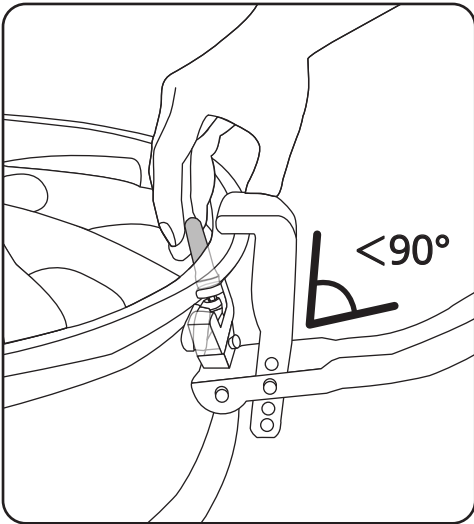

**3** 传感器固定后，请确认眼镜蛇2K的角度小于90°

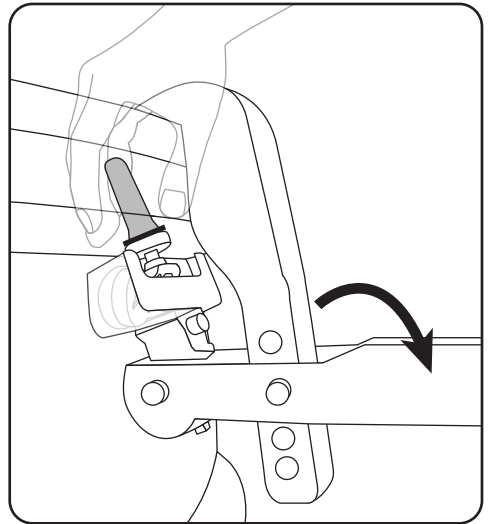

**4** 固定橡胶气嘴，手柄下压将橡胶气嘴安装至正确位置，即完成安装过程。