

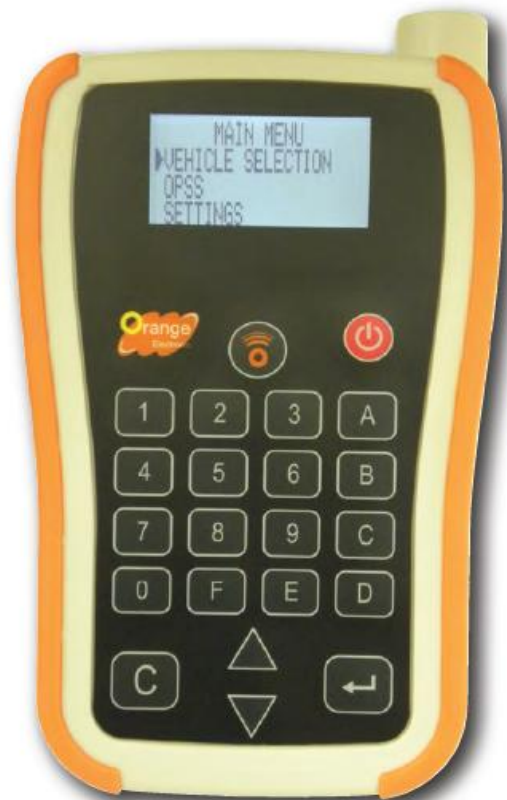

Orange Programmable  
Sensor System

[www.orange-electronic.com](http://www.orange-electronic.com)

# OPSS Generation 2



# OPSS GEN.2 MANUAL

## TABLE OF CONTENTS

- 1. OPSS GENERATION 2 USE .....3
- 2. OPSS INTRODUCTION .....4
  - Power Key .....4
  - Arrow Key .....5
  - Cancel Key .....5
  - Transmit Key .....6
  - Selection Key ..... 6
- 3. COPY ID INSTRUCTION .....7
- 4. ID WRITING INSTRUCTION .....10
- 5. PROGRAM SENSOR INSTRUCTION .....12
- 6. TPMS INSTALL INSTRUCTION .....14
- 7. CHOOSING PREFERRED LANGUAGE .....16
- 8. UPDATING OPSS SOFTWARE .....16
- 9. ADJUSTING OPSS SETTINGS .....17
- 10.TROUBLESHOOTING GUIDE .....18
- 11. APPENDIX .....19
- 12. OPSS SAFETY TIPS .....21
- 13. WARRANTY POLICY .....23
- 14. QUESTIONS .....23



## OPSS GENERATION 2 USE

The Orange Programmable Sensor System, Generation 2 interacts with the tire pressure sensor through wireless (radio frequency) communication to:

- Retrieve data from the tire pressure sensor
- Verify the identities of each tire pressure sensor mounted on vehicle
- Assist a technician to reset TPMS on vehicle

## OPSS INTRODUCTION



= 9 volt battery - install in back of tool prior to operation



= USB Connection - to connect with computer to download software updates

## KEYPAD SUMMARY



Power on and battery status



Transmit key, to force a test cycle



Navigation through menu and adjust parameters up and down



Selection key, press to enter chosen function or validate a parameter





Cancel and power off key, press to return to the previous menu without parameter validation or press and hold to turn off tool



Keypad, key in sensor identification number

## POWER KEY

KEY	FUNCTION
	<p><b>1st Function:</b> press the power key to power on the tool</p> <p><b>Second Function:</b> press and hold power key after powering on to display battery status</p>

FIRST FUNCTION	
At power on, the tool displays the Orange Electronic logo.	
Then it displays the software revision number.	<p>OPSS Version 001-01</p>
Finally, the tool displays the vehicle selection menu.	<p>VEHICLE SELECTION &gt; ACURA AUDI BENTLEY</p>

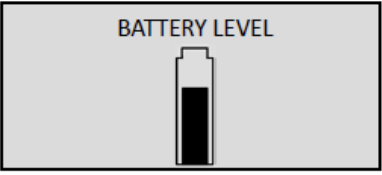
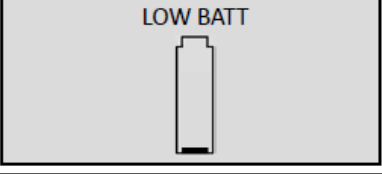
SECOND FUNCTION	
When the tool is powered on, press the power key to display the battery level.	
<p>If the battery power is low, "LOW BATT" will flash and the tool will turn off.</p> <p>Replace the 9V battery to restore power to tool.</p>	

### ARROW KEY

KEY	FUNCTION
	Scroll up/down or increase/decrease numerical values

### CANCEL KEY

KEY	FUNCTION
	<p><b>First Function:</b> press the cancel key to return to previous page without modifying a parameter</p> <p><b>Second Function:</b> press and hold the cancel key for 3 seconds to power off the tool</p>

**TRANSMIT KEY**

KEY	FUNCTION
	Starts the acquisition cycle for a sensor

<p>After selecting vehicle from “Vehicle Selection” on the main menu and the screen indicates “(o) READ SENSOR,” press the transmit key to gather sensor information</p>	<div style="border: 1px solid black; padding: 5px; background-color: #f0f0f0;"> <p style="text-align: center; margin: 0;">HONDA</p> <p style="margin: 0;">(C) RETURN TO MENU</p> <p style="margin: 0;">(o) Start</p> </div>
--	---

**SELECTION KEY**









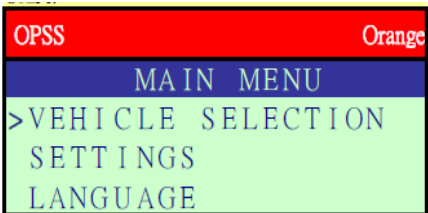

KEY	FUNCTION
	Press the selection key to open a menu, enter a parameter or confirm a parameter

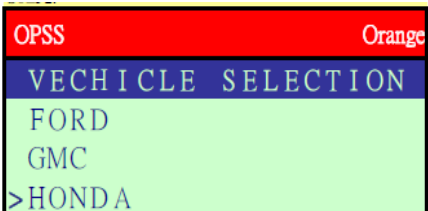

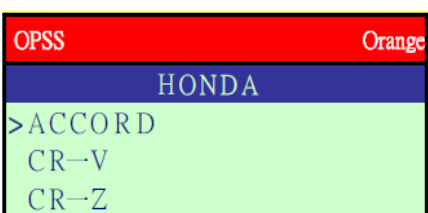



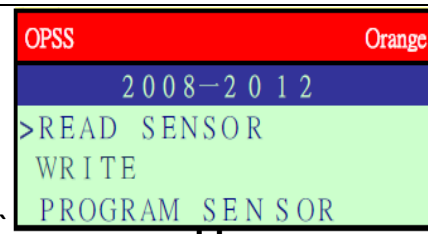

**COPY ID INSTRUCTION**

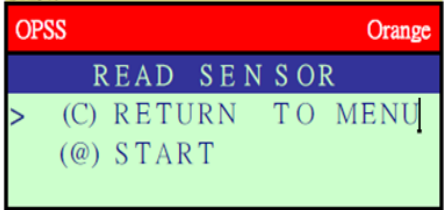
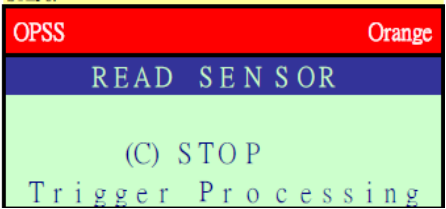
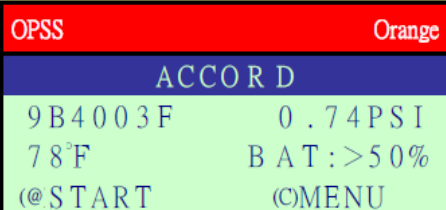
**IMPORTANT:** Before removing tires, use TPMS Application and Cross Reference Guide to determine appropriate Orange sensor needed to replace OE sensors.

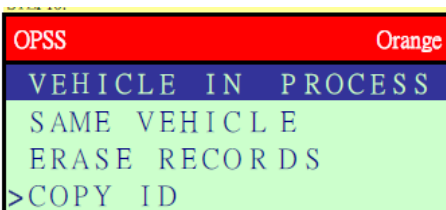
**COPY ID**

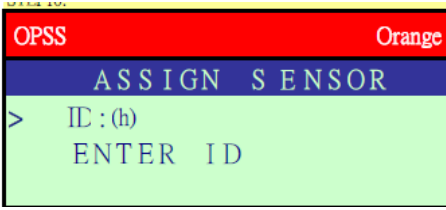
**Note:** Ensure the sensor is **AT LEAST 2 METERS FROM ALL CARS AND TPMS SENSORS (OE OR ORANGE)**

Step	Operating Process	Display Picture
1	To select vehicle modle, press 	
2	Select vehicle maker and press 	
3	Select vehicle modle and press 	
4	Select vehicle production year, and press 	
5	Select the sensor modle, and press 	
6	Put the Original sensor closer to the tool and select READ SENSOR, and press 	

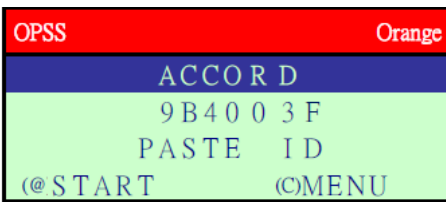
7	Press  to start sensor triggering	
8	Trigger processing, please wait	
9	Processing complete, the sensor's information will show on the display	
10	Press  back to MENU and select COPY ID, and press 	
11	Press  to key in the assigned sensor ID	
12	After key in the assigned sensor ID, press  and select PROG. SENSOR, press  to get started	
13	Put the assigned sensor closer and press  to start ID COPY process	











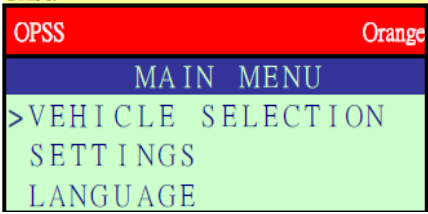

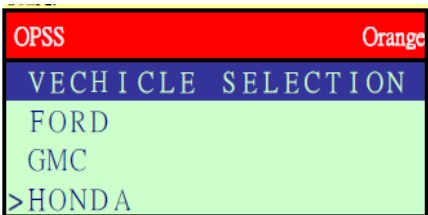

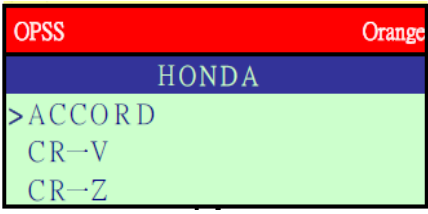



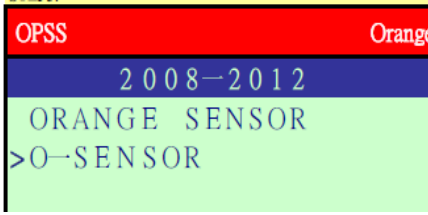

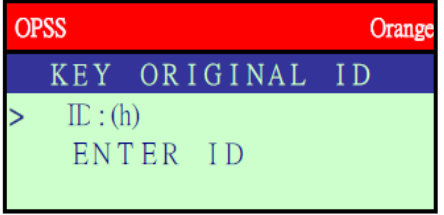

14	Trigger processing, please wait	<p>OPSS Orange          ACCORD          IDENTIFY SENSOR          (C: STOP          TRIGGER PROCESSING</p>
15	Processing complete, the sensor's new information will show on the display	<p>OPSS Orange          ACCORD          9B4003F 0.74PSI          78°F BAT: &gt;50%          @START (CMENU</p>

**ID WRITING INSTRUCTION**

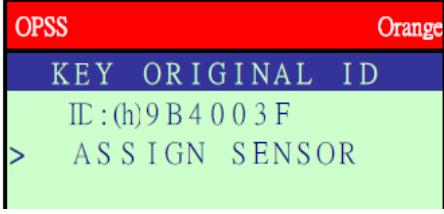
**WRITE ID**

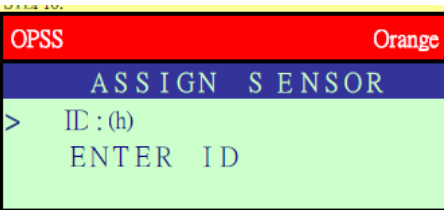
**Note: Ensure the sensor is AT LEAST 2 METERS FROM ALL CARS AND TPMS SENSORS (OE OR ORANGE)**



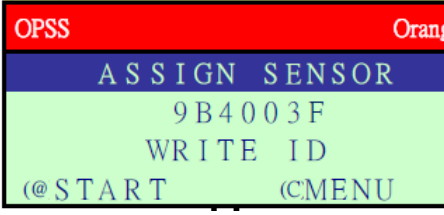
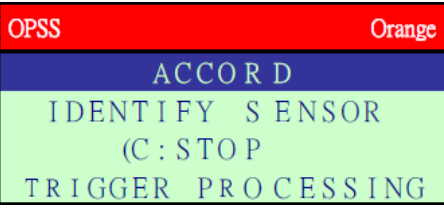
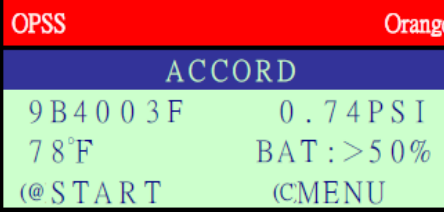





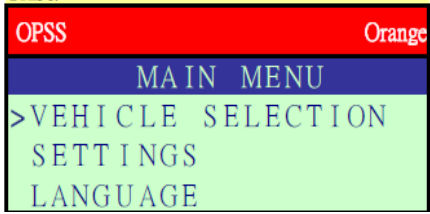

Step	Operating Process	Display Picture
1	To select vehicle modle, press 	
2	Select vehicle maker and press 	
3	Select vehicle modle and press 	
4	Select production year, and press 	
5	Select the sensor modle, and press 	
6	Select WRITE ID, and press 	

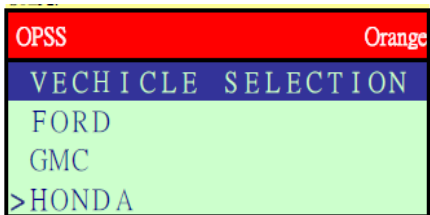

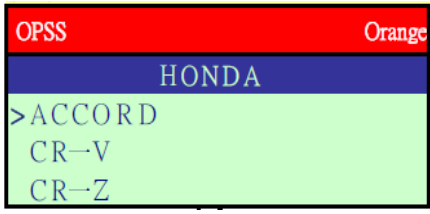

7	Press  to key in the original sensor ID	
8	After key in the original sensor ID, press  and select ASSIGN SENSOR, press  to get started	
9	Press  to key in the assigned sensor ID	
10	After key in the assigned sensor ID, press  and select PROG. SENSOR, press  to get started	
11	Put the assigned sensor closer and press  to start WRITE ID process	
12	Trigger processing, please wait	
13	Processing complete, the sensor's new information will show on the display	

**PROGRAM SENSOR INSTRUCTION**

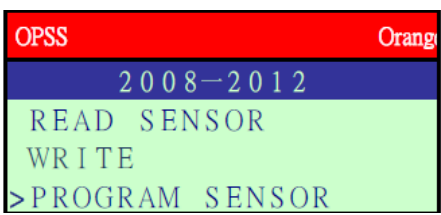
**PROGRAM SENSOR**

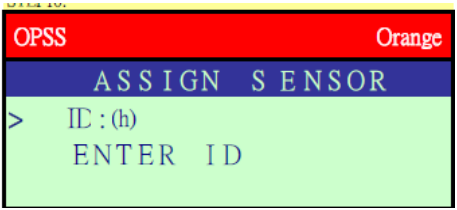

**Note: Ensure the sensor is AT LEAST 2 METERS FROM ALL CARS AND TPMS SENSORS (OE OR ORANGE)**

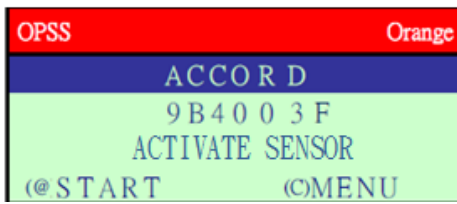
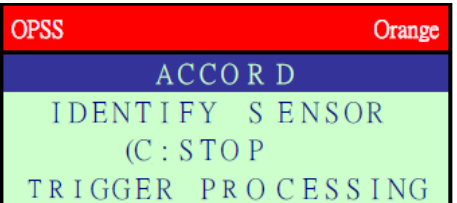
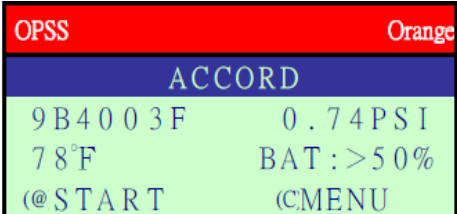
Step	Operating Process	Display Picture
1	To select vehicle modle, press 	
2	Select vehicle maker and press 	
3	Select vehicle modle and press 	
4	Select production year, and press 	
5	Select the sensor modle, and press 	
6	Select PROGRAM SENSOR, and press 	

7	Press  to key in the assigned sensor ID	
8	After key in the assigned sensor ID, press  and select PROG. SENSOR, press  to get started	
9	Put the assigned sensor closer and press  to start PROGRAM SENSOR process	
10	Trigger processing, please wait	
11	Processing complete, the sensor's information will show on the display	

**TPMS Install Instruction**

**TPMS Install Instruction**

Step	Operation Process	Photograph
1	Use a jack to raise the vehicle and place jack stands underneath the vehicle for safety. Refer to vehicle owner’s manual for full service advice. Seek the assistance of a qualified motor mechanic if required.	
2	Take off the tires and bleed the air. Then take off the air valve and the TPMS sensor from the wheel. <b>(NOTE: You must change the valve to new TPMS valve)</b> . This part of the process will normally require the service of a tire fitting service or mechanic.	
3	Use TPMS tool to activate sensor by ID copy or Write ID process <b>BEFORE</b> install the sensor on the wheel  <b>Note 1: to activate the sensor correctly, the distance between sensor and sensor <u>should not be less than 2 meters.</u></b>  <b>Note 2: for the detail information of ID copy or Write ID process, please refer to the TPMS sensor or tool user guide.</b>	

**Clamp-In Metal Valve**

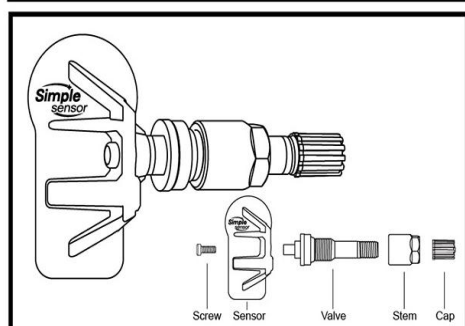

**Clamp-In Metal Valve**

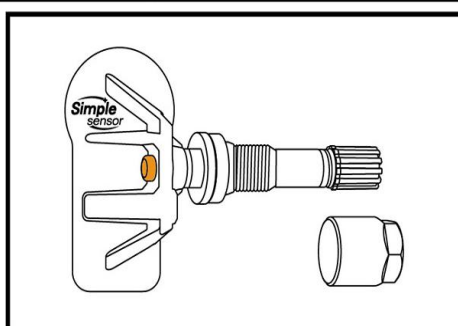

**Step 1:** Insert screw into valve stem tightly (1.3Nm)

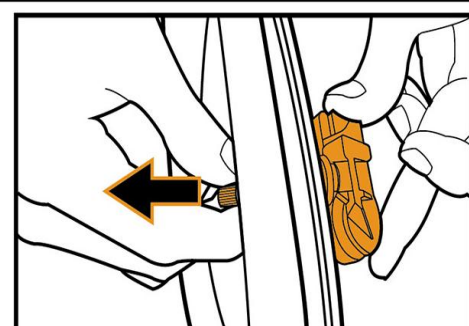

**Step 2:** Insert sensor into valve hole  
\*Ensure sensor close on the surface of wheel alloy

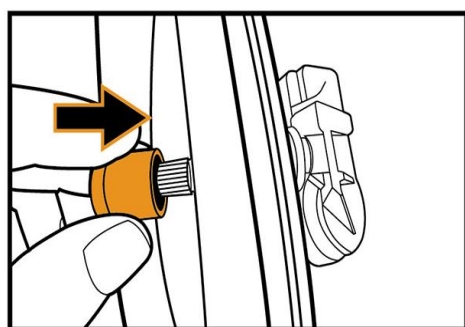

**Step 3:** Insert nut into valve stem

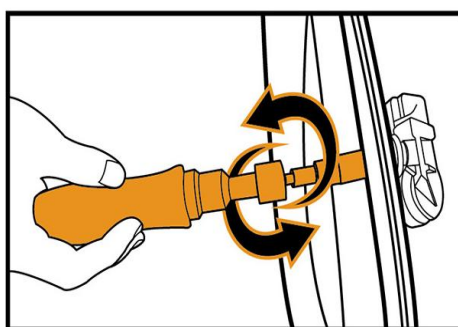

**Step 4:** Tighten nut into valve stem by screwdrivers (4 N.m)

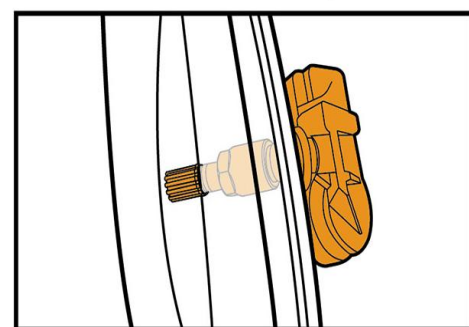

**Installation finished**

Snap-In Rubber Valve

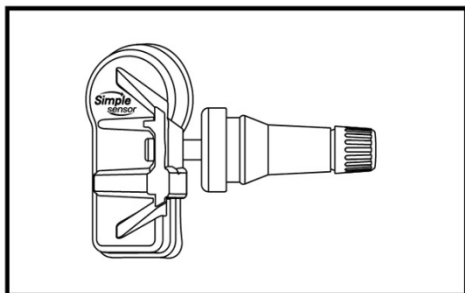

Snap-In Rubber Valve

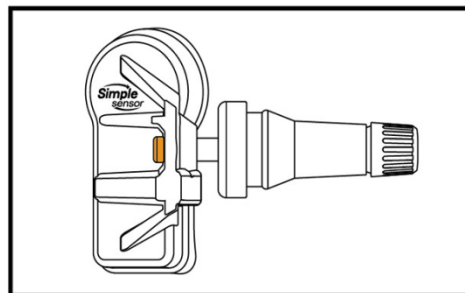
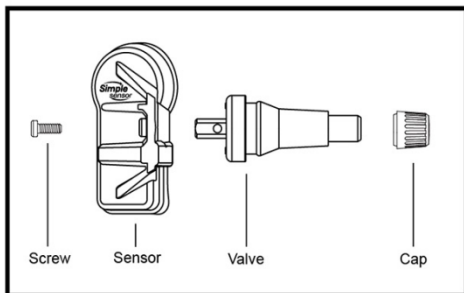

Step 1: Insert screw into valve stem tightly (1.3Nm)

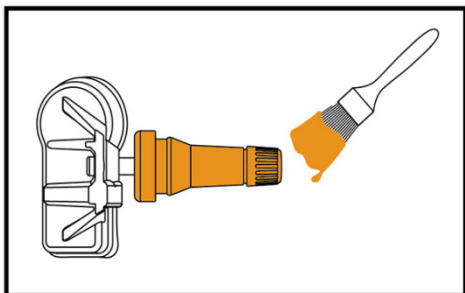

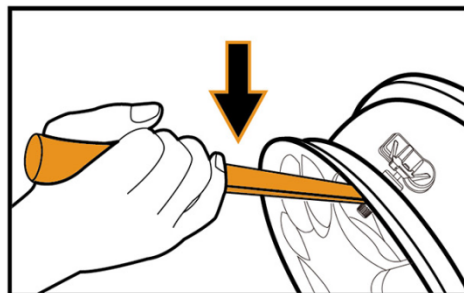

Step 2: Wipe lubricant oil on valve stem

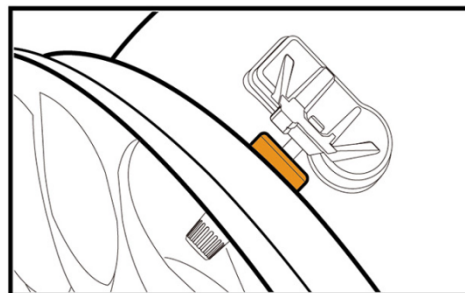

Step 3: Pull valve stem through the valve hole by wrench tool



Step 4: Ensure the end of valve stem touched the rim

6	Inflate the tire.	
7	Balance the tire a. Balance tires using a balance machine b. A lead tire weight may need to be added for balancing. c. Balance until the tire balance shows balance as "OK" The Steps above will require the assistance of a tire fitting service or a mechanic. It is important that the wheels are balanced after the fitting of the TPMS sensors in order to ensure the safe operation of the tire when refitted to the vehicle.	
8	Set up the other three tires in the same manner.	
9	Use the TPMS tool to read the sensors again to detect if the sensors work normally.	

**CHOOSING PREFERRED LANGUAGE**

<p><b>Step 1:</b> From the main menu, select 'Language' with the selection key (↵).</p>	<p>MAIN MENU OPSS SETTINGS &gt; LANGUAGE</p>
<p><b>Step 2:</b> From the language menu, three languages are available for selection: English, Spanish and French.  Use the selection key (↵) select preferred language.</p>	<p>LANGUAGE &gt; ENGLISH ESPANOL FRANCAIS</p>
<p><b>Step 3:</b> Once the preferred language has been chosen, display will automatically return to main menu.</p>	<p>MAIN MENU &gt; VEHICLE SELECTION OPSS SETTINGS</p>

**UPDATING OPSS SOFTWARE**

To access the latest software version for your OPSS Generation 2 Tool, please visit:

[http://update.ateq.com/software/tpms/orange/webvt\\_install.zip](http://update.ateq.com/software/tpms/orange/webvt_install.zip)

**NOTICE**

This device complies with Part 15 of the FCC Rules and with RSS-210 of industry Canada.

Operation is subject to the following two conditions:

- (1) This device may not cause harmful interference
- (2) This device must accept any interference received, including interference that may cause undesired operation

**Warning: Any changes or modifications in construction of this device which are not expressly approved by the party responsible for compliance could void the user's authority to operate the equipment.**



## ADJUSTING OPSS SETTINGS

<p><b>Step 1:</b> From the main menu, select 'Settings' with the selection key (↵).</p>	<pre> MAIN MENU VEHICLE SELECTION OPSS &gt; SETTINGS                     </pre>
<p><b>Step 2:</b> Use the up and down arrow keys (↑/↓) and select (↵) the feature to be adjusted.</p> <p><i>Note:</i> After adjusting setting, use the (C) key to return to main menu.</p>	<pre> SETTINGS &gt; UNITS : kPA / °C   FORMAT: AUTO   BUZZER ON : YES                     </pre>
<p><b>Units:</b> Press the selection key (↵) to enter unit selection and use the arrow keys (↑/↓) to highlight desired units (kPa/°C or PSI/°F) and select with (↵).</p>	<pre> UNITS SELECTION &gt; kPA / °C   PSI / °F                     </pre>
<p><b>Format:</b> Change the display format between decimal and hexadecimal with (↑/↓). The preset setting is AUTO that automatically changes format based on input.</p>	<pre> FORMAT &gt; AUTO   DECIMAL   HEXADECIMAL                     </pre>
<p><b>Buzzer:</b> User can select if the tool will vibrate after receiving tire sensor information. Scroll to 'BUZZER ON' on settings scree, press selection key (↵) and use arrows (↑/↓) to toggle between 'YES' or 'NO.'</p>	<pre> SETTINGS UNITS : PSI / °F FORMAT : AUTO BUZZER ON : YES &lt;                     </pre>
<p><b>Backlight/Contrast:</b> User can adjust the brightness and contrast of display. Press selection key (↵) to move cursor to right of display and use the arrows (↑/↓) to adjust ±1%.</p> <p><i>Tip:</i> a brighter display will consume battery more quickly</p>	<pre> SETTINGS BUZZER ON : YES BACKLIGHT : 60% CONTRAST : 55% &lt;                     </pre>
<p><b>Auto-off:</b> User can adjust how quickly the tool will turn off after a period of non-use. This feature can also be disabled. Press select (↵) to move cursor to right of display and use arrow keys to select desired auto-off amount of time.</p>	<pre> SETTINGS BACKLIGHT : 60% CONTRAST : 55% &gt; AUTO OFF : DISABLED                     </pre>
<p><b>Zone:</b> User can modify the zone between America, Europe, Asia and Other.</p>	<pre> SETTINGS CONTRAST : 55% AUTO OFF : 1 MIN &gt; ZONE : AMERICA                     </pre>







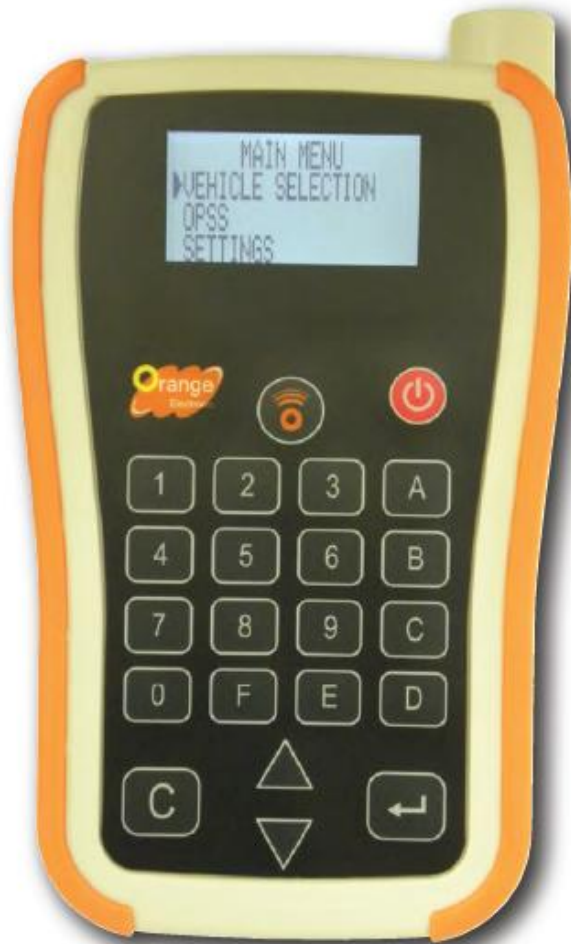

## TROUBLESHOOTING GUIDE

PROBLEM	SOLUTION
TPMS light remains on after installation of new sensors	<p>May require over-inflating tire and then reducing psi to proper level to activate sensor(s).</p> <p>Spare tire may be equipped with TPMS. Check vehicle owner's manual to verify if TPMS monitors spare tire. If so, ensure proper air pressure and functioning sensor in spare tire.</p>
Newly written ID number on Orange sensor does not match the OE ID number after using 'COPY ID'	<p>Check your format in settings. Change to appropriate format. Hexadecimal reads ID number in alphanumeric format (numbers and letters) while decimal format reads ID number in only numeric format (numbers only).</p> <p>Try writing the sensor manually (page 9) or go through the auto relearn process.</p>
Scanning sensor and 'NO SENSOR DETECTED' appears on screen	<ul style="list-style-type: none"> <li>- Try repositioning the OPSS Gen. 2 tool</li> <li>- Ensure correct sensor is being used via the "TPMS Application &amp; Complete Cross Reference Guide."</li> <li>- Verify that the OE part number in the "TPMS Application &amp; Cross Reference Guide" matches the OE part number of the sensor on the vehicle</li> </ul>
TPMS lamp is illuminated in vehicle after removing damaged OE sensors	Remove uninstalled OE sensors from area, damaged sensors will continue to transmit signal
'NO SENSOR DETECTED' appears on screen during COPY ID process	See Page 12, Step 8 to verify correct ID
'USE A MAGNET TO ACTIVATE SENSOR' or 'RELEASE PRESSURE TO ACTIVATE SENSOR' appears on screen	Stay on the same screen, place a magnet on sensor valve stem or release pressure from tire accordingly, then press transmit (🔴)

**APPENDIX**

<b>OPSS TECHNICAL SPECIFICATIONS</b>	
<b>Dimensions</b>	152mm x 82mm x 33mm
<b>Battery</b>	9V
<b>Communications port:</b>	USB
<b>Display:</b>	4 line LCD, 65mm x 32mm
<b>Weight:</b>	220g
<b>Temperatures:</b>	Operational: 5°C to 45°C / 41°F to 113°F Storage: 0°C to 60°C / 32°F to 140°F
<b>Relative humidity:</b>	70-80%



OPSS Safety Tips	
	<p><b>SWITCH ON SAFELY</b></p> <p>Do not switch on the device when wireless tool is prohibited or when it may cause interference or danger.</p>
	<p><b>SWITCH OFF WHEN REFUELING</b></p> <p>Do not use the device when filling vehicle with gasoline. Do not use near fuel or chemicals.</p>
	<p><b>SWITCH OFF NEAR BLASTING</b></p> <p>Adhere any restrictions. Do not use the tool when blasting is in progress.</p>
	<p><b>USE SENSIBLY</b></p> <p>Use only in normal conditions as indicated in product instructions. Do not touch the antenna unnecessarily.</p>
	<p><b>QUALIFIED SERVICE</b></p> <p>Only qualified personnel may install or repair this device.</p>
	<p><b>ENHANCEMENTS AND BATTERIES</b></p> <p>Use only approved enhancements and batteries for the OPSS tool. Do not connect incompatible products.</p>
	<p><b>WATER RESISTANCE</b></p> <p>The tool is not water resistant - keep it dry.</p>
	<p><b>CONNECTING TO OTHER DEVICES</b></p> <p>When connecting to any other device, read user guide for detailed safety instructions. Do not connect incompatible products.</p>



**This device is a radio transmitter and receiver.**

## OPSS CARE AND MAINTENANCE

The OPSS tool is a product of superior design and craftsmanship and should be treated with care. Follow the suggestions below to help maintain warranty coverage:

- Keep the device dry. Precipitation, humidity and all types of moisture may contain minerals that will corrode electronic circuits. If device does get wet, remove the battery and allow the device to dry completely before replacing.
- Do not use or store the tool in dusty, dirty areas to keep electronic components clean.
- Do not store the device in hot areas. High temperatures can shorten the life of electronic devices, damage batteries and warp or melt certain plastics.
- Do not store the device in cold areas. When the device returns to its normal temperature, moisture can form inside the device and damage electronic circuit boards.
- Do not attempt to open the device other than instructed in this guide.
- Do not drop, knock or shake the device. Rough handling can break internal circuit boards and mechanics.
- Do not use harsh chemicals, cleaning solvent or strong detergent to clean the device. Do not paint the device. Paint can clog the moving parts and prevent proper operation.
- Do not touch the main display with hard or angular materials. Objects like earrings or jewelry may scratch the display.
- Use a soft, clean and dry cloth to clean the device.
- Use only the supplied antenna. Unauthorized antennas, modifications or attachments could damage the device and may violate regulations governing radio devices.
- The power connection cord is NOT COMPATIBLE with a USB interface. Please do not use with any USB devices

All of the above suggestions apply equally to your device, battery or any enhancements. If device is not working properly, contact Orange Electronic N.A.

## RF CERTIFICATION INFORMATION

This device meets guidelines for exposure to radio waves.

This device is a radio transmitter and receiver. It is designed not to exceed the limits for exposure to radio waves recommended by international guidelines. These guidelines were developed by the independent scientific organization ICNIRP and include safety margins designed to assure the protection off all persons, regardless of age and health.

For further information see ICNIRP "guidelines for limiting exposure to time-varying electric, magnetic and electromagnetic fields (up to 300 GHz)" or contact Orange Electronic N.A.

The SAR value for this device is less than 5A/m. This value is the reference level for general public exposure to time varying electric and magnetic fields (unperturbed rms values) for the 3-150 kHz frequency range.

## WARRANTY POLICY

Orange Electronic products are guaranteed from material defects for 365 days after the Date of purchase. If the product fails under normal circumstances within the first year, Orange Electronic will repair or replace the product. Product will not be replaced or repaired if damaged from misuse or incorrect application. To obtain repair or replacement of the product under warranty, please contact Orange Electronic. Proof of purchase and date of purchase are required to validate the warranty claim.

Orange Electronic is not liable for any direct or consequential loss or property damage arising from use of product.

**Note: Warranty does not cover tire valves or screws for tire valves. The tire valves and screws need to be replaced when rotating tires, changing tires or changing the TPMS sensors. If installing/reinstalling a TPMS sensor, new valves and screws should be used.**

**Warning: Only use Orange Electronic replacement parts. Using other brands will not allow the system to work and void the warranty.**

## QUESTIONS

Any questions pertaining to warranty information or other questions not answered in the preceding pages can be answered by the OPSS 2 place of purchase or by Orange Electronic's service phone or e-mail address:

**+1855.OEC.TPMS (855.632.8767)**

[serviceusa@orange-electronic.com](mailto:serviceusa@orange-electronic.com)

For update TPMS information and Orange products, visit the Orange Electronic website:

[www.orange-electronic.com](http://www.orange-electronic.com)

---

Thank you for your purchase and enjoy your new Orange Programmable Sensor System!



[www.orange-electronic.com](http://www.orange-electronic.com)

**Tel: 310 377 8835**

**Toll free for U.S. & Canada: 1866-492-4170**